

Human Cervical Cancer

Over 1,200 deaths per year in the U.K. alone

Caused by infection with
Human Papilloma Virus (HPV)

High risks HPV types

Geographical and other considerations

Human cervical cancer

Selective targeting of the HPV virus may permit selective targeting of the cancer cells without adverse side effects upon normal cells.

i.e. raises the possibility of a drug which enters all cells but which only kills the HPV-positive cancer cells.

RNA interference

-destroys mRNA expressed from target genes

-self-replicating process

-highly selective

-induced by small ds RNA molecules

Aim: to selectively destroy
viral mRNA

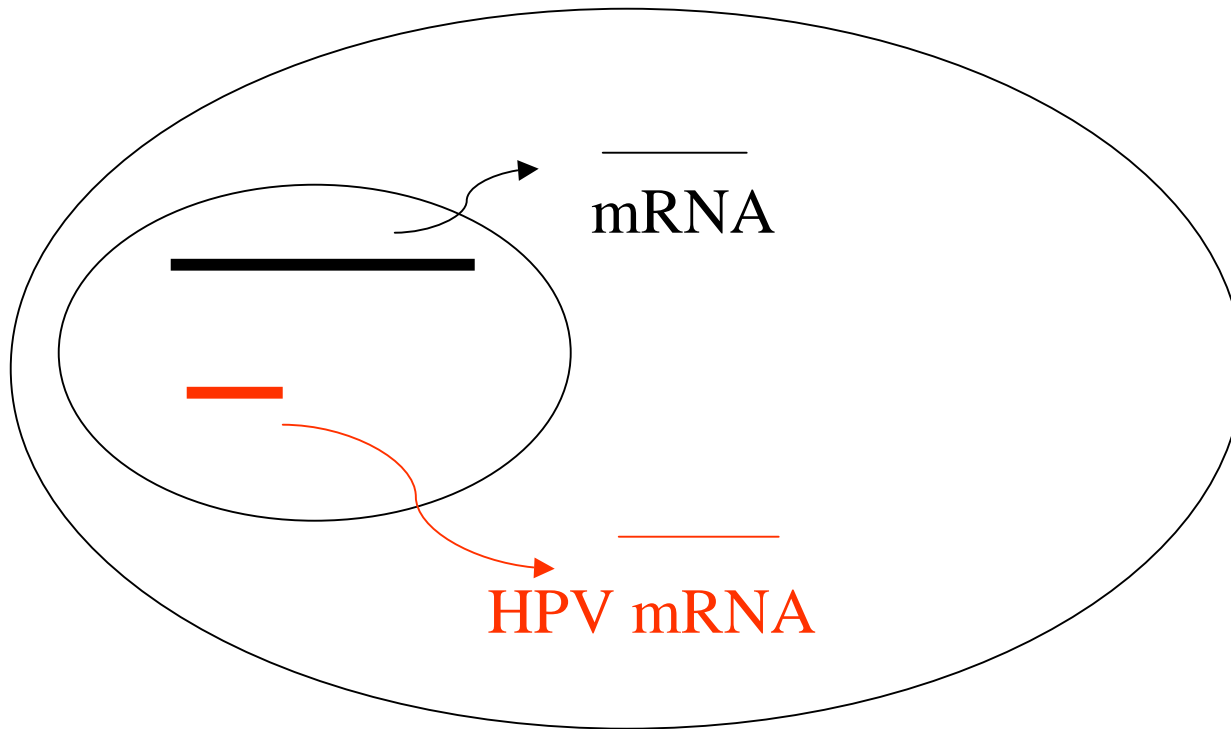

Choice of viral target gene(s)

E6

E7

These two viral genes are the driving force of malignancy

Infection

Pre-malignant

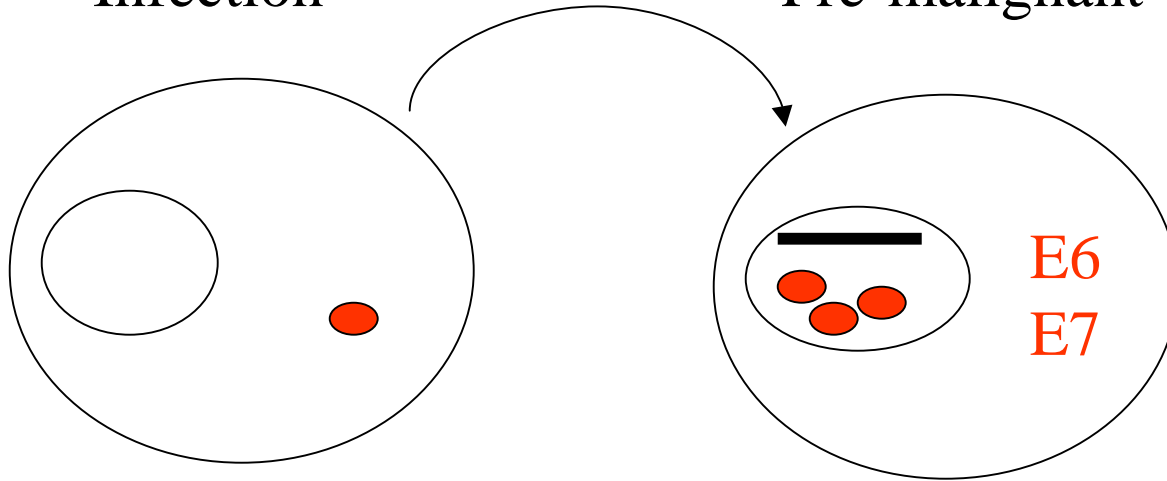

Malignant

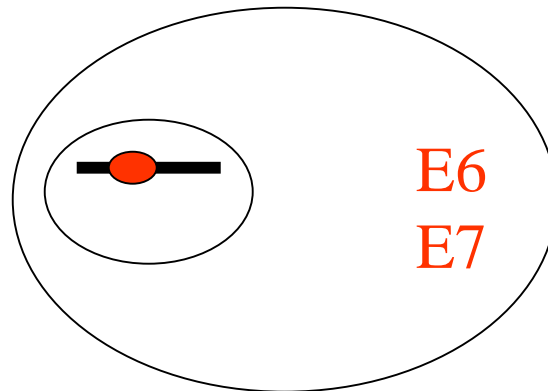

● = Viral genome

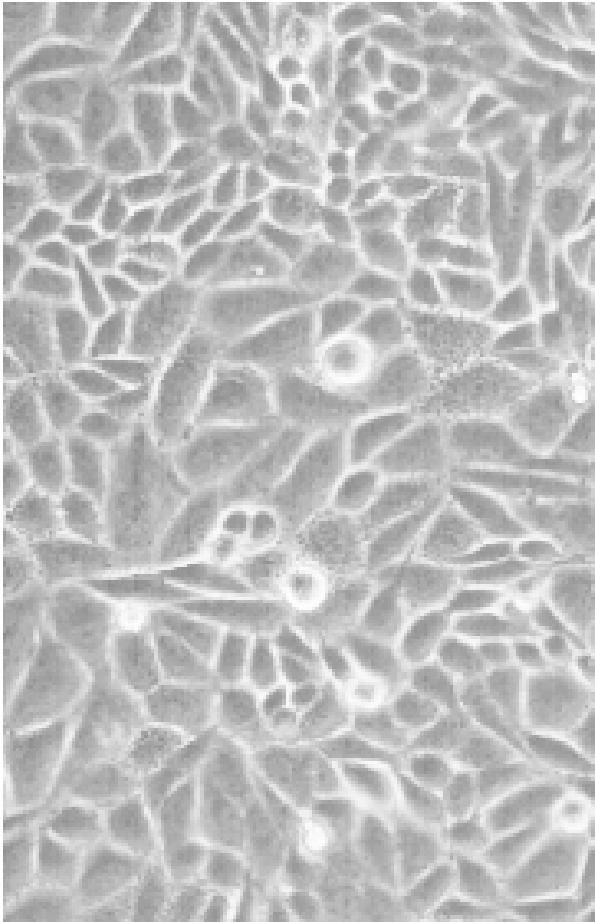

Human
cervical cancer
cells growing
in cell culture
(HPV-16)

E6 mRNA

1

477

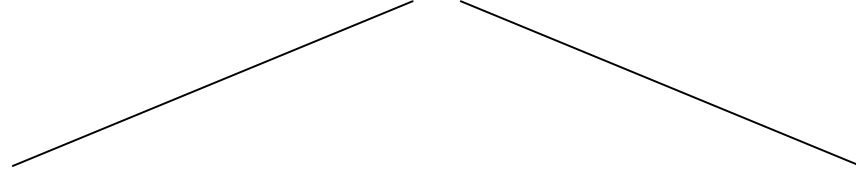

Dimer Loop

E6

5'-GAGGUAUAUGACUUUGCUUTT

-0.1

0

siRNA

TTCUCCAUAUACUGAAACGAA-5'

-0.4

0

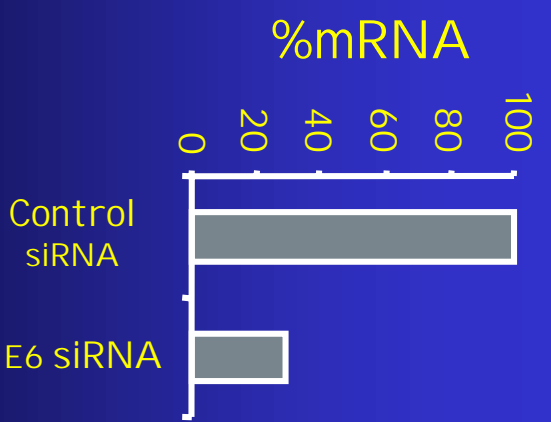
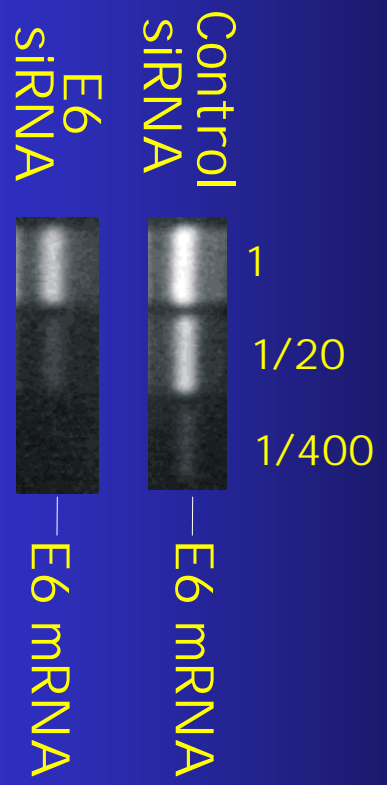
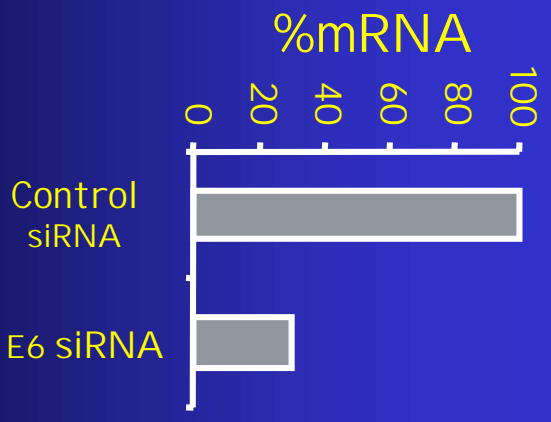
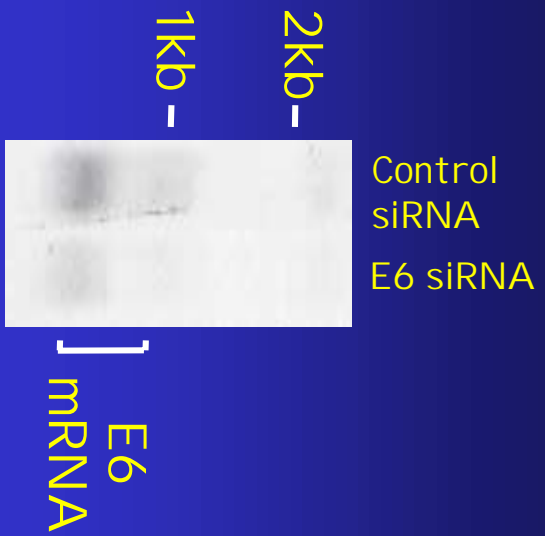

E6 siRNA induce activation of p53

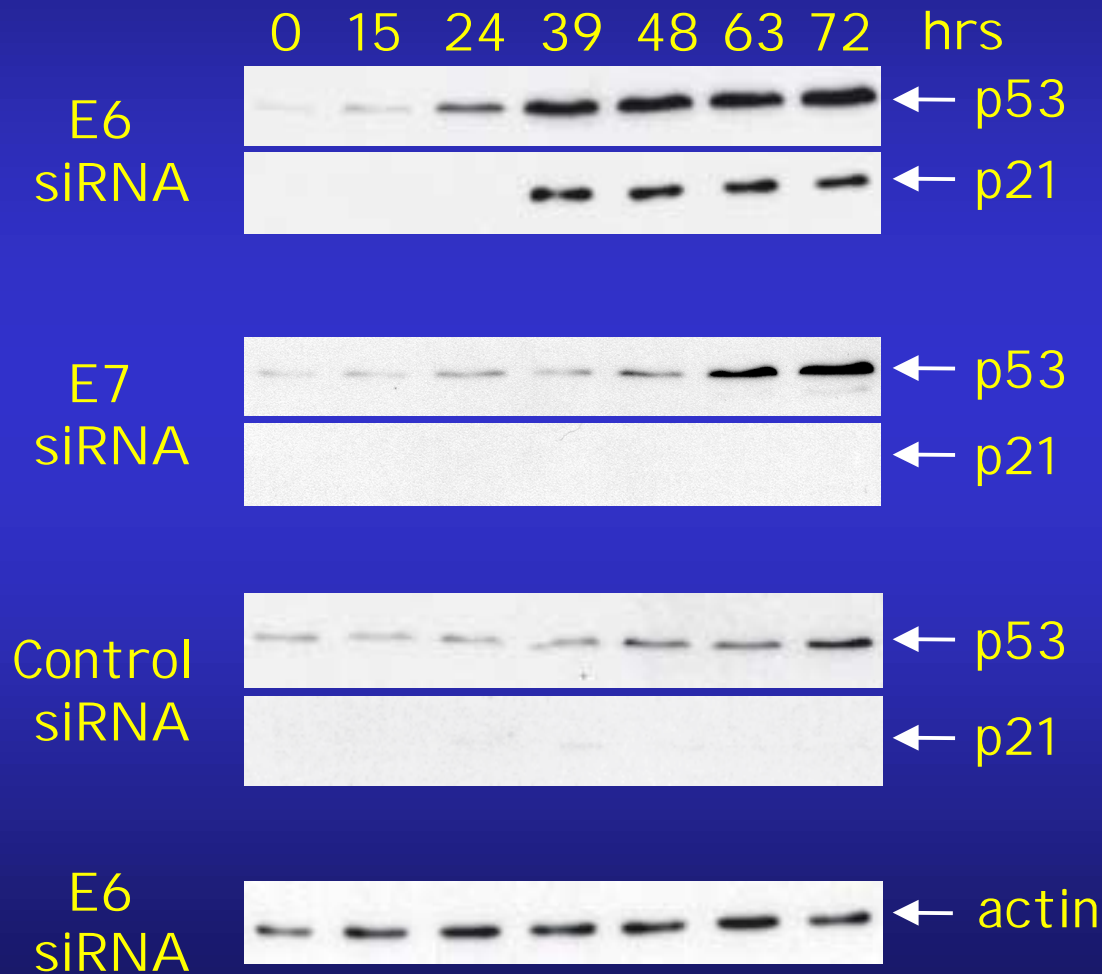

Control
siRNA

E6
siRNA

48hrs

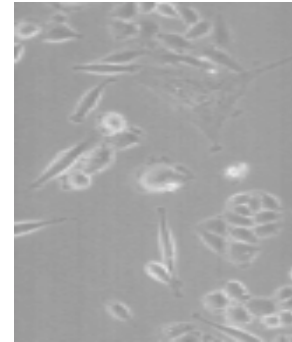
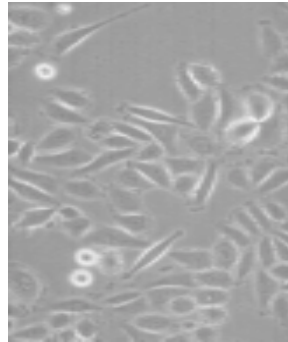

72hrs

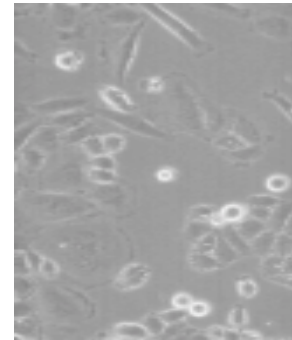
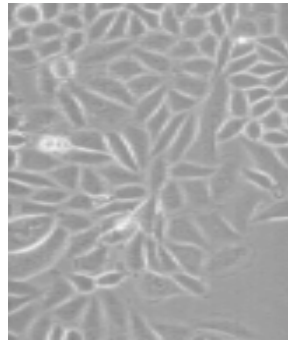

96hrs

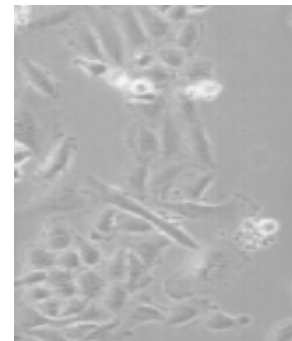
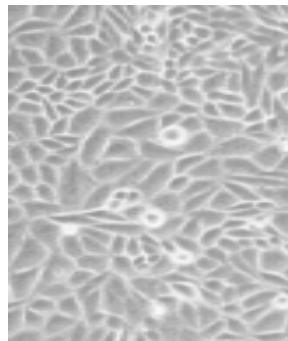

Human papilloma virus

E6

E7

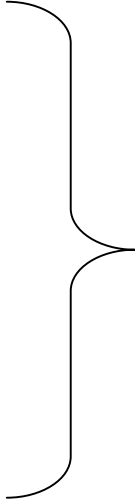

E6 and E7
co-operate
to transform
cell growth

E7 siRNA causes apoptosis of cervical cancer cells

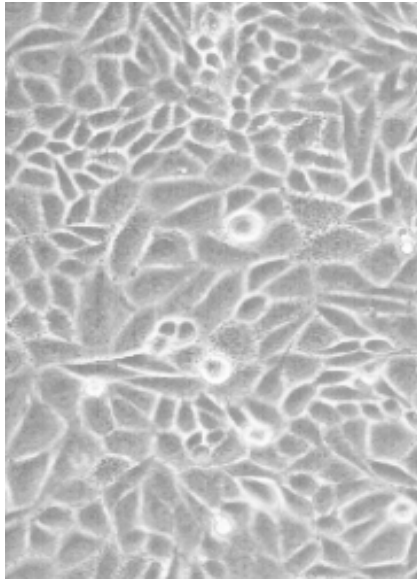

Control siRNA

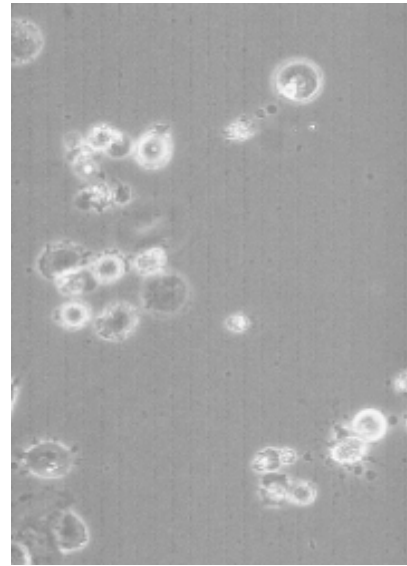

E7 siRNA

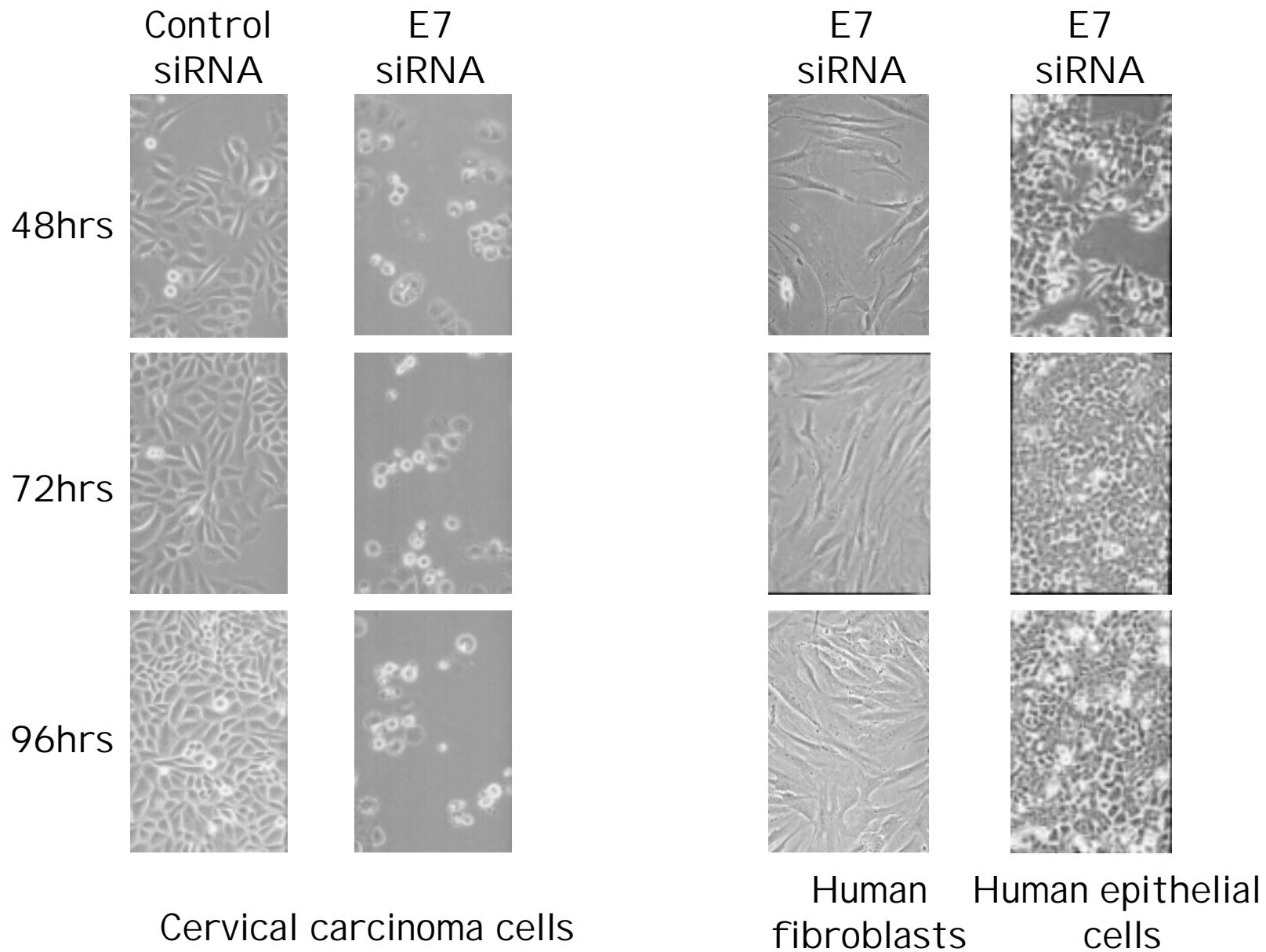

Implications for anti-cancer therapy

- highly specific
- siRNA easily synthesised
- requires no modification to improve efficacy
- different HPV types

RNA therapy for human cervical cancer ?

Jo Milner & Ming Jiang

Yorkshire Cancer Research p53 Laboratory
University of York, UK