

# Functional Implications of Alternative System Designs: Genetic Switches and Signal Transduction Modules

**Michael A. Savageau**

**The University of California, Davis**

**June 2003**

**“The problems faced by pre- and post-genomic genetics are ... much the same -- they all involve bridging the chasm between genotype and phenotype.”**

**-- Sydney Brenner, *Science* 287:2173 (2000)**

# Function of Gene Circuitry

- **Superficial answer**
  - ◆ Genotype determined by the information encoded in the DNA sequence
  - ◆ Phenotype by the context-dependent expression of the genome
  - ◆ Circuitry interprets context and orchestrates expression
- **Deeper answer**
  - ◆ Hierarchy of mechanisms
  - ◆ Diversity of design issues
  - ◆ Accident and rule

# Research Program

- **Development of mathematical tools and approaches appropriate for biological systems**
  - ◆ Nonlinear mathematical formalisms and analysis
  - ◆ Computational algorithms
- **Applications to generic classes of biological systems at the molecular and cellular level**
  - ◆ Metabolic pathways
  - ◆ Gene circuits
  - ◆ Immune networks
- **Long-term goal of understanding biological design principles**
  - ◆ Re-design for therapeutic purposes
  - ◆ Optimization for technological purposes

# The Organism: *Escherichia coli*

- Robust
- Versatile
- Efficient
- Responsive



# The Environments: In Here and Out There

**Colon type**

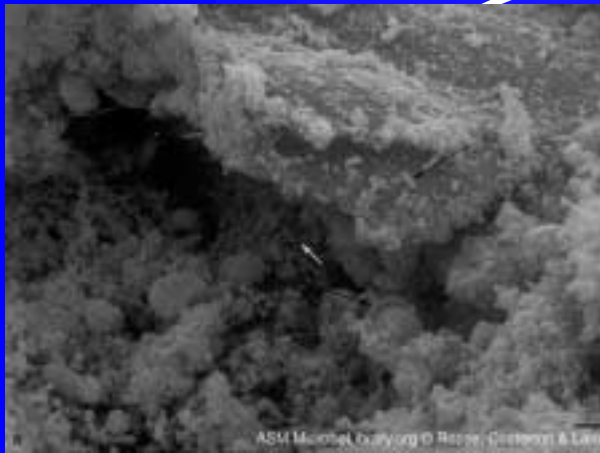

**Aquatic type**

# Outline

- **Background**
  - ◆ **Methodology**
  - ◆ Demand theory example
- Genetic Switches
  - ◆ Design
  - ◆ Switching times
  - ◆ Robustness
- Two-Component Systems
  - ◆ Design
  - ◆ Function
  - ◆ Structure

# Approach

- **Emphasize large classes of circuits with a specific function**
  - ◆ Inducible catabolic circuits in bacteria
  - ◆ ~100 members
  - ◆ Many tests of any general prediction
- **Goals**
  - ◆ Understand the basis for nearly universal designs
  - ◆ Discover rules for distinguishing alternative designs

# Requirements for the Elucidation of System Design Principles

- **Canonical nonlinear representation**
- **Constraints that reduce the space of meaningful comparison**
- **Methods for extracting implications implicit in the system equations**
- **Quantitative criteria for judging functional effectiveness**

# Systemic Manifestations of the Power-Law Formalism

- Generalized-Mass-Action Representation

$$\frac{dX_i}{dt} = \sum_{k=1}^r \alpha_{ik} \prod_{j=1}^n X_j^{g_{ijk}} - \sum_{k=1}^r \beta_{ik} \prod_{j=1}^n X_j^{h_{ijk}}$$

- Synergistic-System Representation

$$\frac{dX_i}{dt} = \alpha_i \prod_{j=1}^n X_j^{g_{ij}} - \beta_i \prod_{j=1}^n X_j^{h_{ij}}$$

# Mathematically Controlled (“Ideal”) Comparisons

- **Two designs are represented in a canonical nonlinear formalism**
- **Differences are restricted to a single specific process**
- **One design is chosen as the reference**
- **Internal equivalence is maintained**
- **External equivalence is imposed**
- **The systems are characterized by rigorous mathematical and computer analysis**
- **Comparisons are made on the basis of quantitative criteria for functional effectiveness**

# Outline

- **Background**
  - ◆ Methodology
  - ◆ **Demand theory example**
- Genetic Switches
  - ◆ Design
  - ◆ Switching times
  - ◆ Robustness
- Two-Component Systems
  - ◆ Design
  - ◆ Function
  - ◆ Structure

# Dual Modes of Gene Control

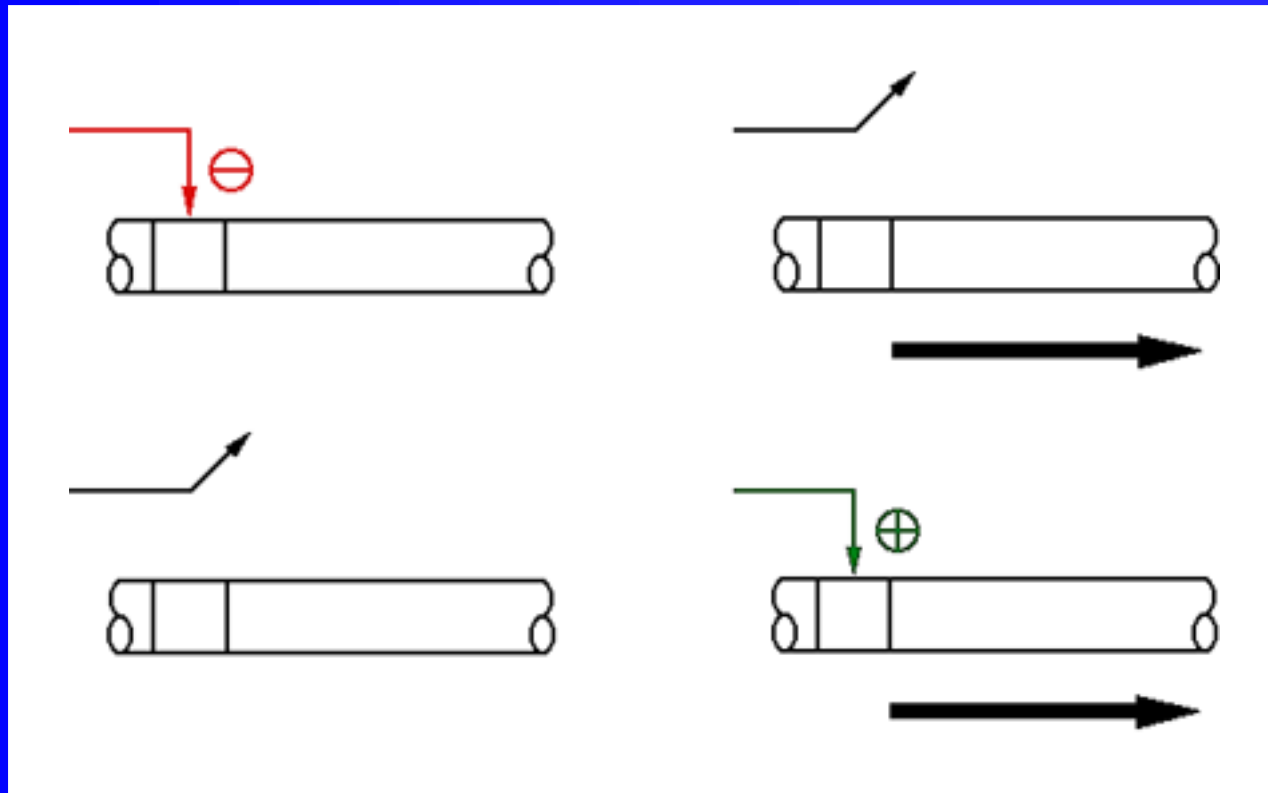

# Mutation and Selection

## A Negative Regulation in Environment H

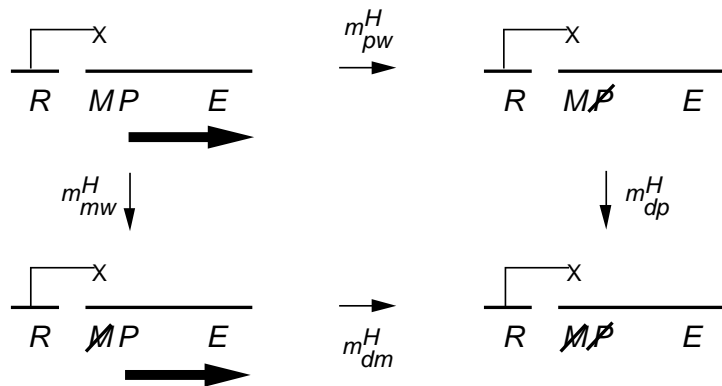

## B Negative Regulation in Environment L

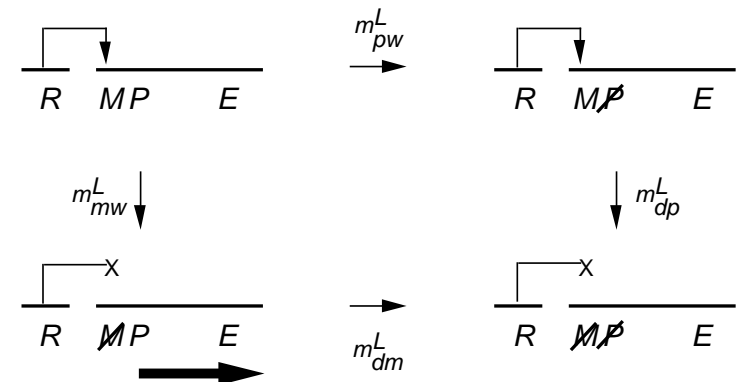

# Demand Theory of Gene Control

- A **positive** mode of control is predicted when there is a **high** demand for expression of a gene
- A **negative** mode of control is predicted when there is a **low** demand for expression of a gene

# Molecular Mode of Gene Control

- **Experimental evidence**
  - ◆ **Single demand functions** >100
  - ◆ **Logical coupling of functions** ~ 20
  - ◆ **Differentiated cell-specific functions** ~ 6

M. Savageau, *PNAS* 74:5647 (1977)

# LYTIC PHAGE $\lambda$

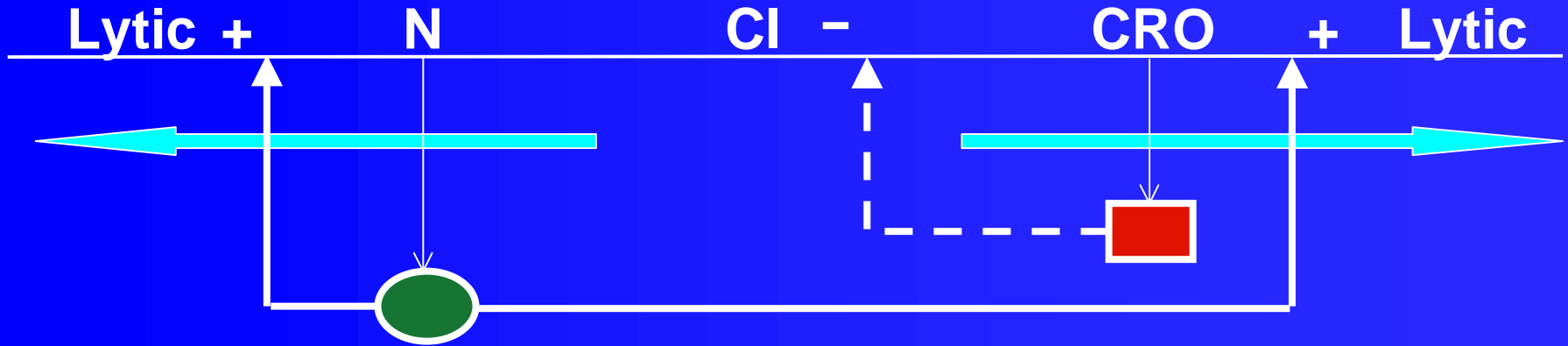

# LYSOGENIC PHAGE $\lambda$

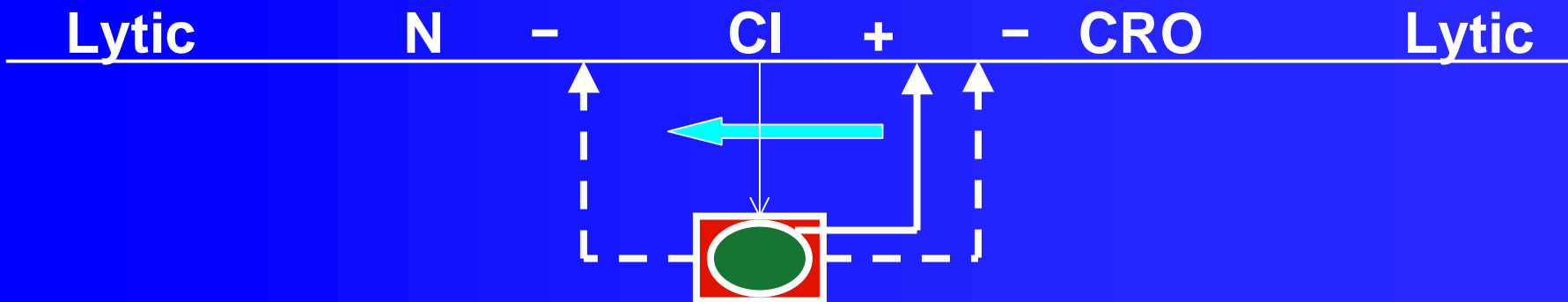

# Outline

- Background
  - ◆ Methodology
  - ◆ Demand theory example
- **Genetic Switches**
  - ◆ **Design**
  - ◆ Switching times
  - ◆ Robustness
- Two-Component Systems
  - ◆ Design
  - ◆ Function
  - ◆ Structure

# Two Types of Switches

## Static

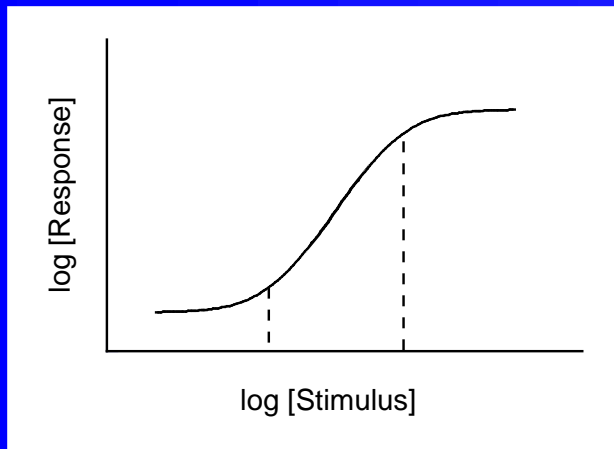

## Dynamic

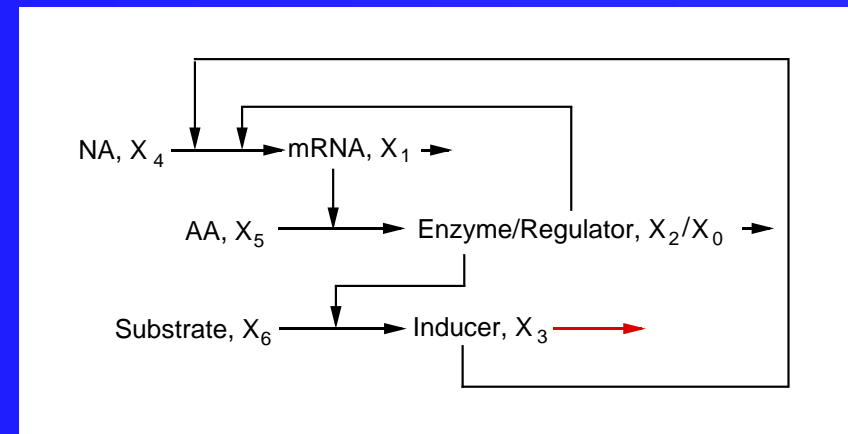
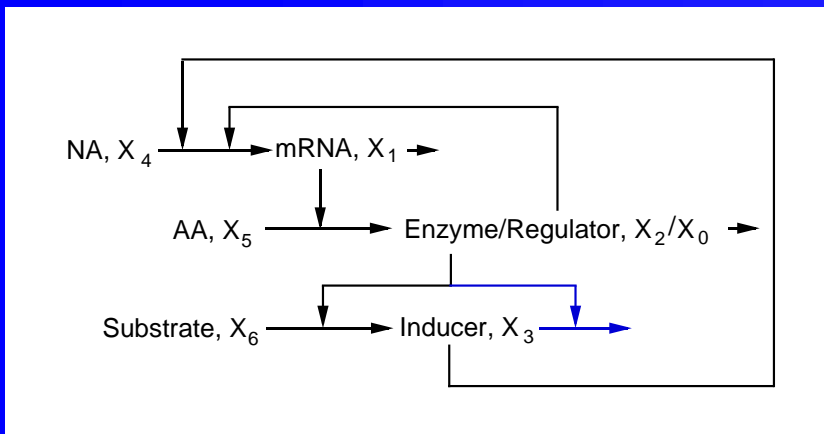
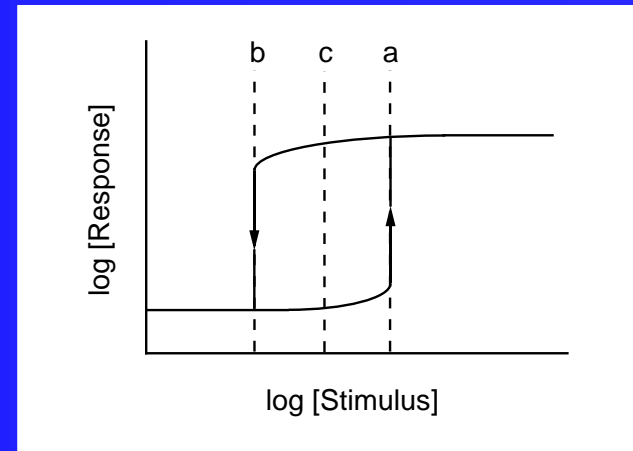

# Equations

## Static

$$\frac{dX_1}{dt} = \alpha_{1B} - \beta_1 X_1 \quad X_3 < X_{3L}$$

$$\frac{dX_1}{dt} = \alpha_1 X_2^{g_{12}} X_3^{g_{13}} - \beta_1 X_1 \quad X_{3L} < X_3 < X_{3H}$$

$$\frac{dX_1}{dt} = \alpha_{1M} - \beta_1 X_1 \quad X_{3H} < X_3$$

$$\frac{dX_2}{dt} = \alpha_2 X_1 - \beta_2 X_2$$

$$\frac{dX_3}{dt} = \alpha_3 X_2^{g_{32}} X_4^{g_{34}} - \beta_3^S X_2^{h_{32}^S} X_3^{h_{33}^S}$$

## Dynamic

$$\frac{dX_1}{dt} = \alpha_{1B} - \beta_1 X_1 \quad X_3 < X_{3L}$$

$$\frac{dX_1}{dt} = \alpha_1 X_2^{g_{12}} X_3^{g_{13}} - \beta_1 X_1 \quad X_{3L} < X_3 < X_{3H}$$

$$\frac{dX_1}{dt} = \alpha_{1M} - \beta_1 X_1 \quad X_{3H} < X_3$$

$$\frac{dX_2}{dt} = \alpha_2 X_1 - \beta_2 X_2$$

$$\frac{dX_3}{dt} = \alpha_3 X_2^{g_{32}} X_4^{g_{34}} - \beta_3^D X_3^{h_{33}^D}$$

# Constraints for External Equivalence

## Equal switching effort

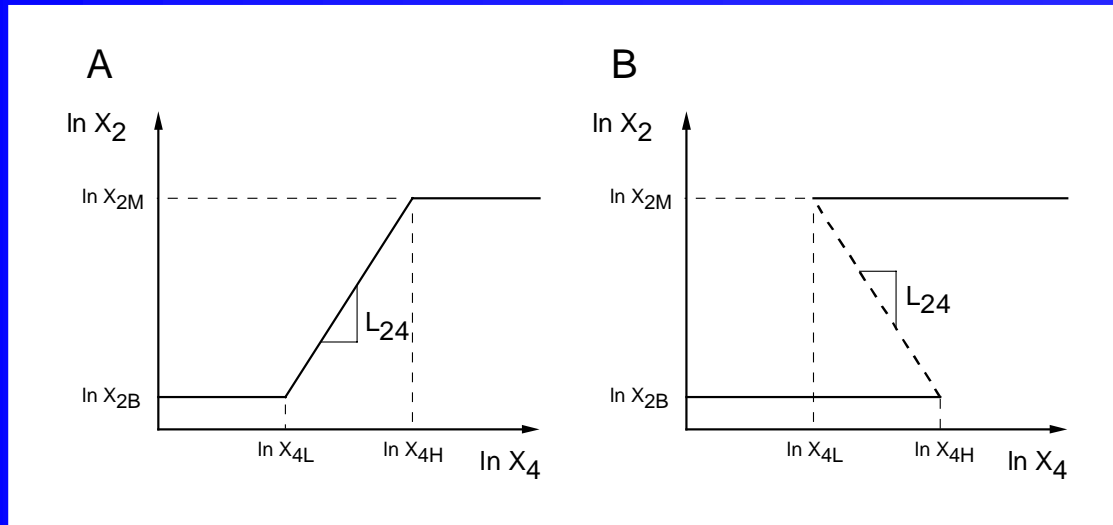

## Unique parameters

$$h_{33}^D = [g_{21}g_{13}(2g_{32} - h_{32}^S) / (h_{11} - g_{12}g_{21})] - h_{33}^S$$

$$\beta_3^D = \beta_3^S \left[ \left( \frac{\sqrt{\alpha_{1B}\alpha_{1M}}}{\beta_1} \right) \left( \frac{\alpha_2}{\beta_2} \right) \frac{h_{11}}{g_{21}} \right] \left( \frac{2g_{21}g_{34}}{h_{11}L_{24}^S} \right) \left[ \left( \frac{\alpha_1}{\beta_1} \right) \left( \frac{\alpha_2}{\beta_2} \right) \frac{h_{11}}{g_{21}} \right] \left[ \frac{g_{21}(2g_{32} - h_{32}^S)}{h_{11} - g_{12}g_{21}} - \frac{2h_{33}^S}{g_{13}} \right]$$

# Design Space

## Repressor control

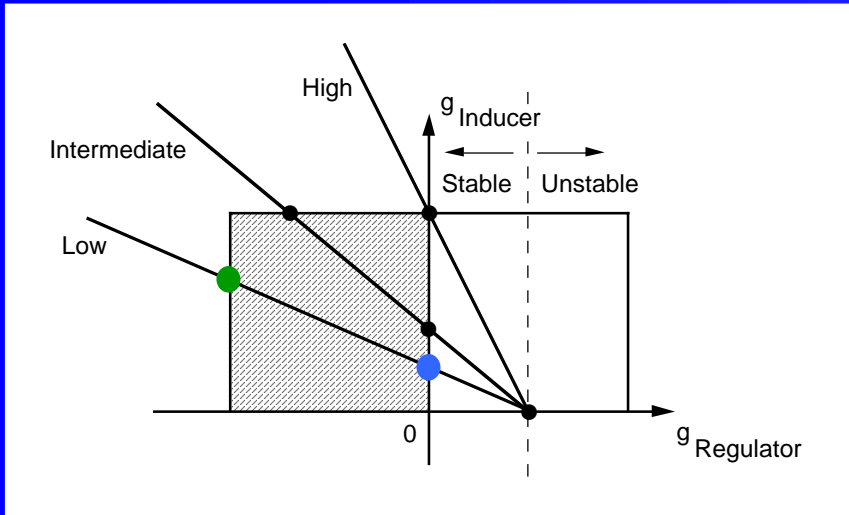

## Activator control

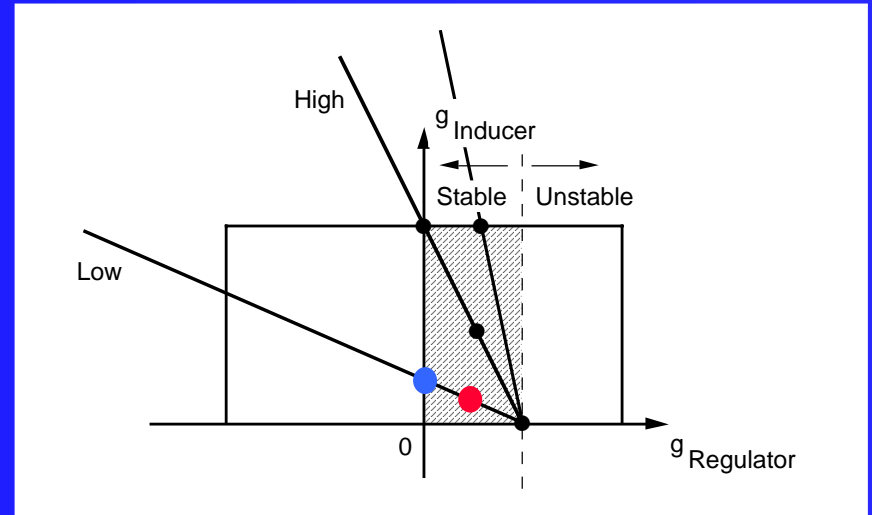

## Line of equivalence

$$g_{13} = \frac{h_{11}h_{22}h_{33}L_{24}}{g_{21}g_{34}} - \frac{h_{33}L_{24}}{g_{34}} g_{12}$$

# Outline

- Background
  - ◆ Methodology
  - ◆ Demand theory example
- **Genetic Switches**
  - ◆ Design
  - ◆ **Switching times**
  - ◆ Robustness
- Two-Component Systems
  - ◆ Design
  - ◆ Function
  - ◆ Structure

# Response Time

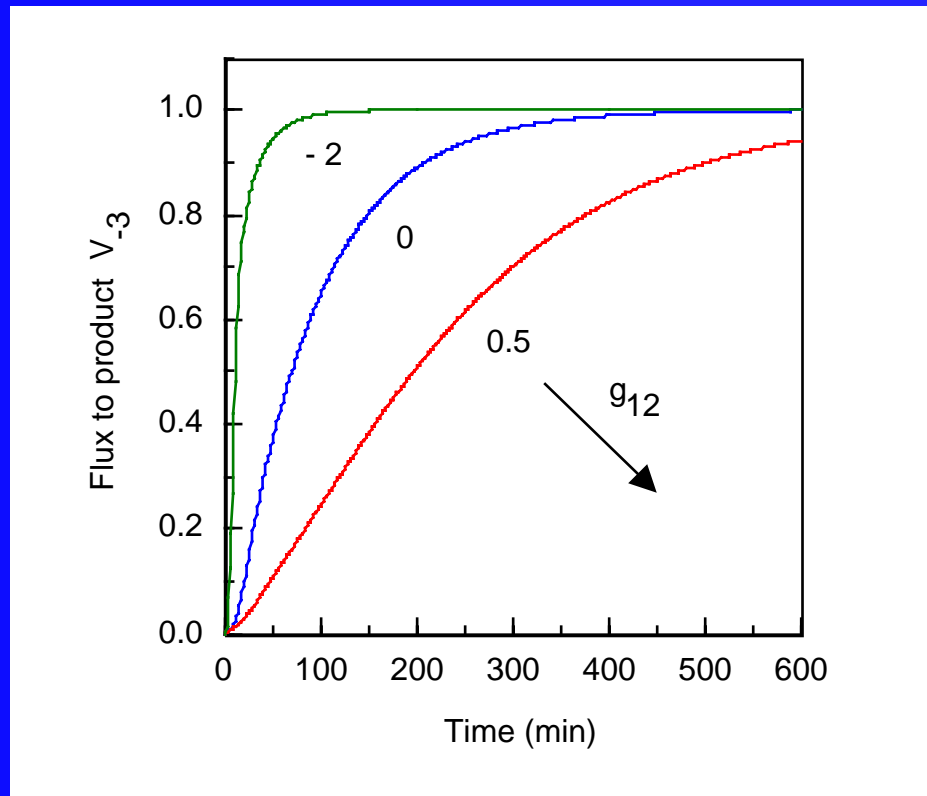

# Comparison of Switching Times

ON

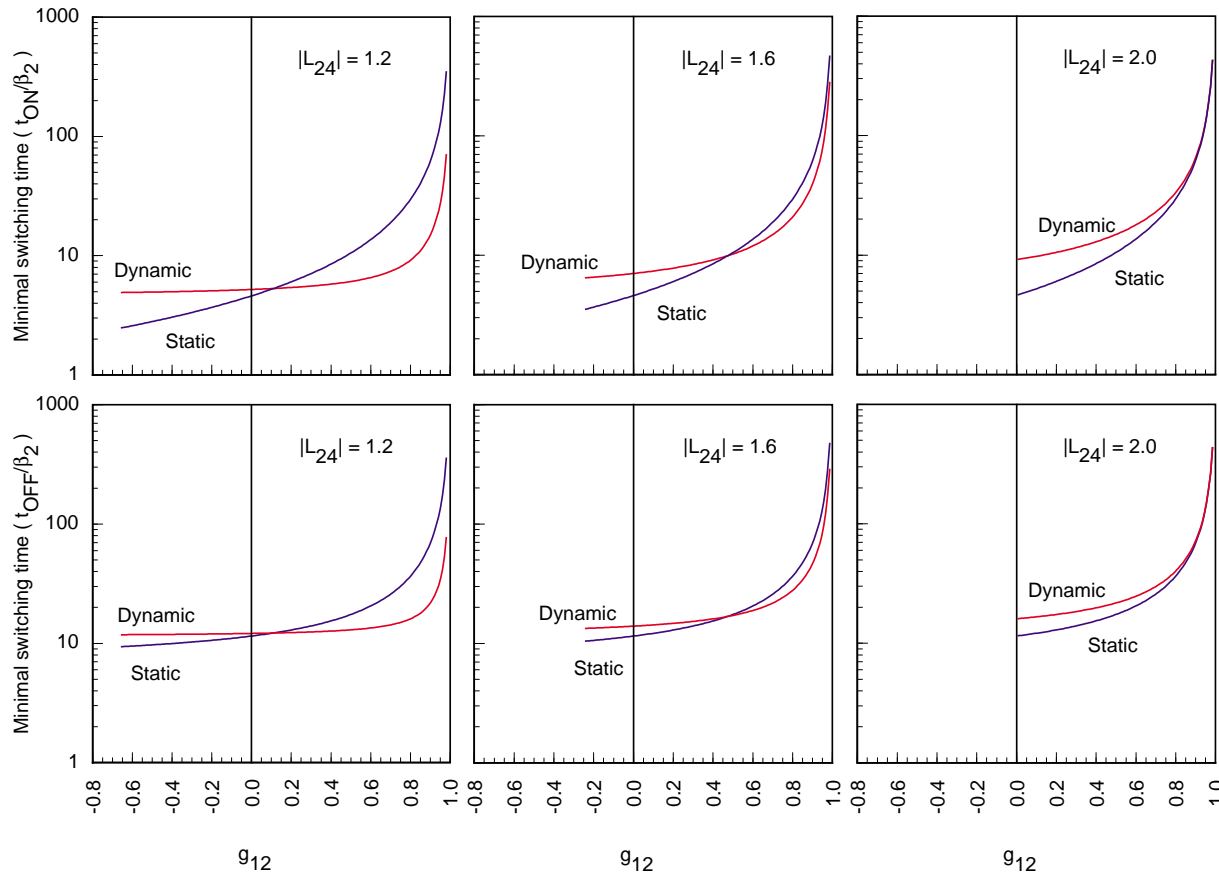

OFF

# Outline

- Background
  - ◆ Methodology
  - ◆ Demand theory example
- **Genetic Switches**
  - ◆ Design
  - ◆ Switching times
  - ◆ **Robustness**
- Two-Component Systems
  - ◆ Design
  - ◆ Function
  - ◆ Structure

# Aggregate Parameter Sensitivities

Threshold	Switch Type	
	Static	Dynamic
Low	0.64	1.81
High	1.03	1.28

# Biological Predictions

- **Static switch has faster switching times**
- **ON times are faster than OFF times in all cases**
- **Static switch has more robust thresholds**
- **Static switch has more robust switching times**
- **Thus, natural inducers are predicted to occupy intermediate positions in the inducible pathway**
- **Experimental evidenced supports this prediction**

# Outline

- Background
  - ◆ Methodology
  - ◆ Demand theory example
- Genetic Switches
  - ◆ Design
  - ◆ Switching times
  - ◆ Robustness
- **Two-Component Systems**
  - ◆ **Design**
  - ◆ Function
  - ◆ Structure

# Alternative Designs for Sensors of Two-Component Systems

Bifunctional sensor

Monofunctional sensor

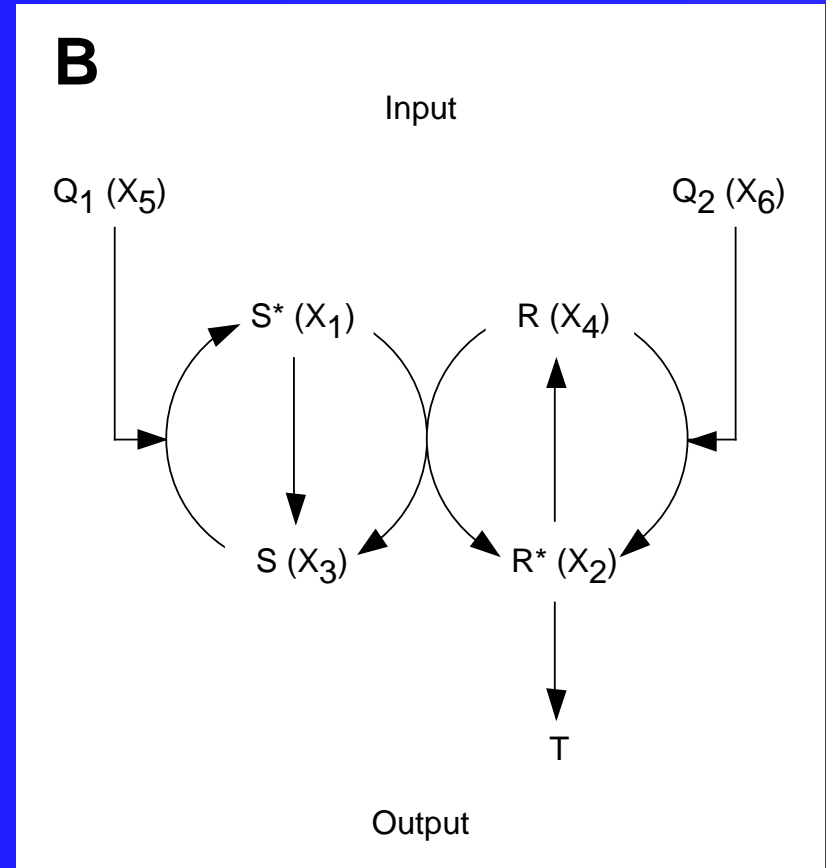
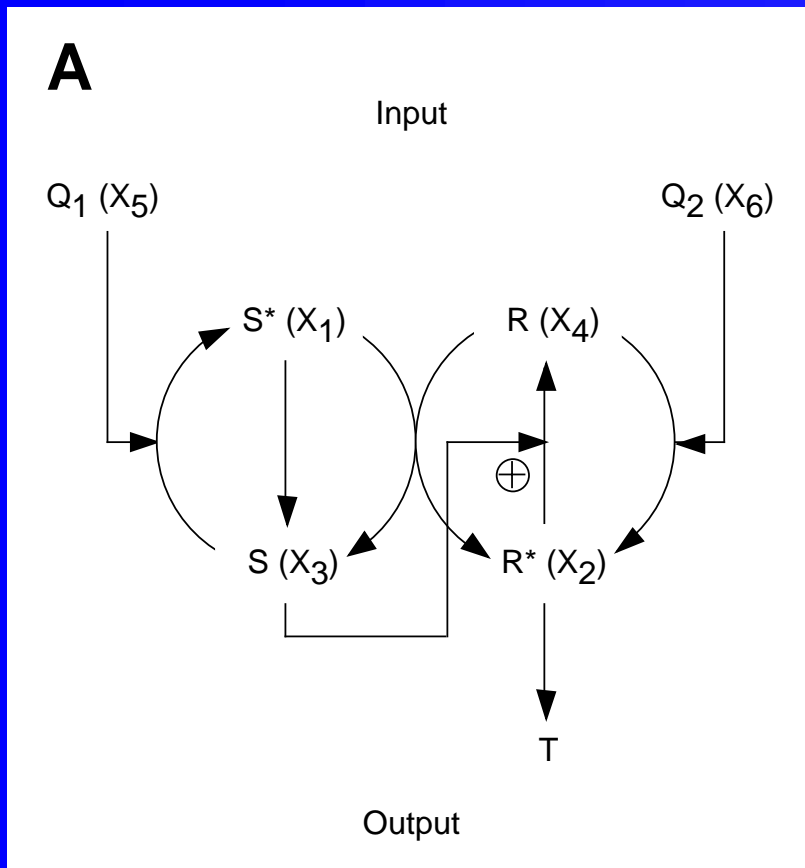

# Outline

- Background
  - ◆ Methodology
  - ◆ Demand theory example
- Genetic Switches
  - ◆ Design
  - ◆ Switching times
  - ◆ Robustness
- **Two-Component Systems**
  - ◆ Design
  - ◆ **Function**
  - ◆ Structure

# Equations

Bifunctional sensor

$$dX_1 / dt = \alpha_{10} X_1^{g_{11}} X_5^{g_{15}} X_7^{g_{17}} - \beta_{10} X_1^{h_{11}} X_2^{h_{12}} X_8^{h_{18}}$$

$$dX_2 / dt = \alpha_{20} X_1^{g_{21}} X_2^{g_{22}} X_6^{g_{26}} X_8^{g_{28}} - \beta_{20} X_1^{h_{21}} X_2^{h_{22}} X_7^{h_{27}}$$

Monofunctional sensor

$$dX_1 / dt = \alpha_{10} X_1^{g_{11}} X_5^{g_{15}} X_7^{g_{17}} - \beta_{10} X_1^{h_{11}} X_2^{h_{12}} X_8^{h_{18}}$$

$$dX_2 / dt = \alpha_{20} X_1^{g_{21}} X_2^{g_{22}} X_6^{g_{26}} X_8^{g_{28}} - \beta_{20} X_2^{h_{22}}$$

# Constraints for External Equivalence

## Signal amplification

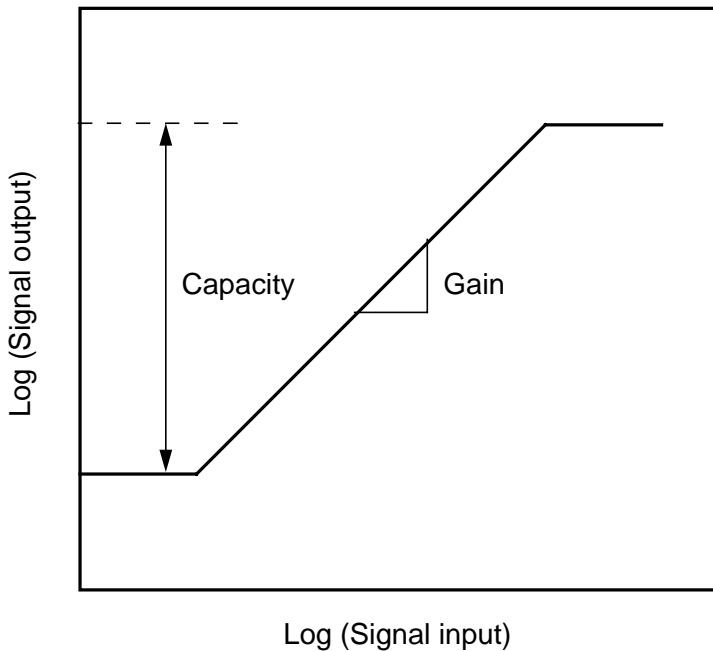

## Unique parameters

$$h'_{22} = \frac{g_{15}g_{21}h_{22} + g_{26}h_{11}h_{22} - g_{15}g_{22}h_{21} - g_{26}h_{12}h_{21} - g_{11}g_{26}h_{22}}{g_{15}g_{21} + g_{26}h_{11} - g_{11}g_{26} - g_{15}h_{21}}$$

$$\log \beta'_{20} = \frac{\left( \begin{aligned} &g_{15}h_{21} \log \alpha_{20} - (g_{15}g_{21} - g_{26}(g_{11} - h_{11})) \log \beta_{20} \\ &+ g_{26}h_{21} \log (\beta_{10} / \alpha_{10}) + g_{15}g_{26}h_{21} \log (X_6 / X_5) \\ &+ (g_{26}(h_{27}(g_{11} - h_{11})) - g_{15}g_{21}h_{27} - g_{17}g_{26}h_{21}) \log X_7 \\ &+ h_{21}(g_{15}g_{28} + g_{26}h_{18}) \log X_8 \end{aligned} \right)}{g_{26}(g_{11} - h_{11}) + g_{15}(h_{21} - g_{21})}$$

# Functional Predictions

- **Bifunctional sensors**
  - ◆ Attenuate secondary signals
  - ◆ Suppress noisy cross-talk
- **Monofunctional sensors**
  - ◆ Amplify secondary signals
  - ◆ Integrate functional cross-talk

# Alternative Designs for Sensors of Two-Component Systems

## Noise Suppression

## Signal Integration

**C**

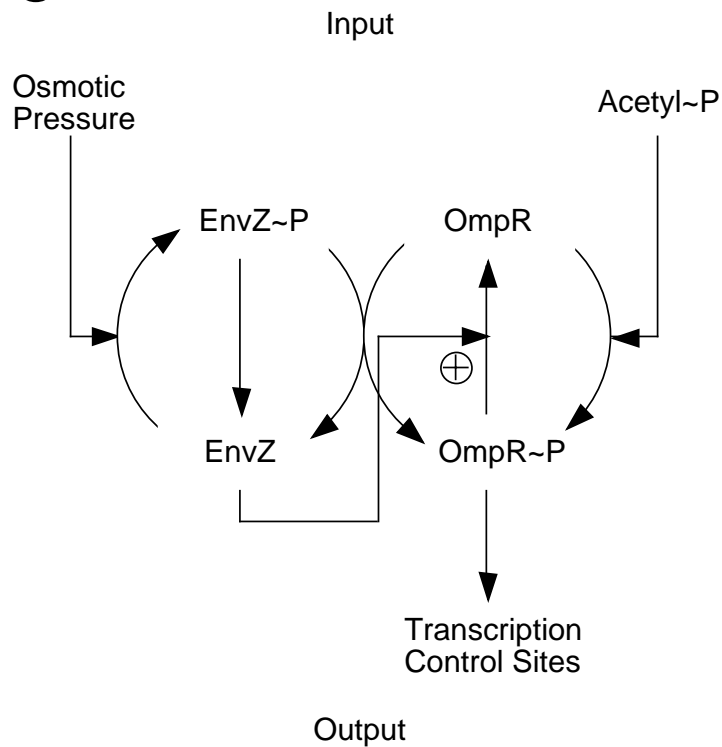

**D**

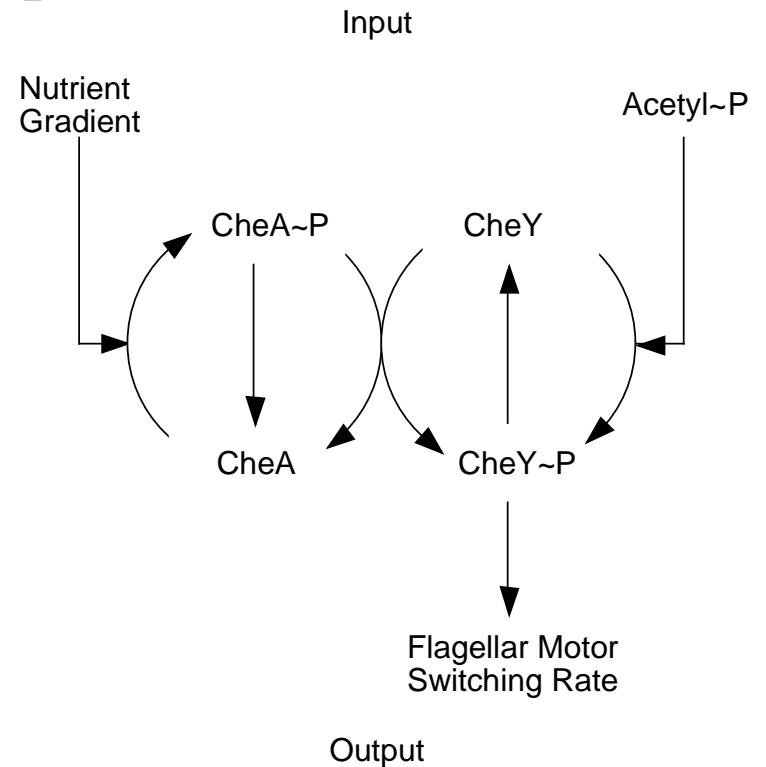

# Outline

- Background
  - ◆ Methodology
  - ◆ Demand theory example
- Genetic Switches
  - ◆ Design
  - ◆ Switching times
  - ◆ Robustness
- **Two-Component Systems**
  - ◆ Design
  - ◆ Function
  - ◆ **Structure**

# Alternative Designs for Sensors of Two-Component Systems

Bifunctional sensor

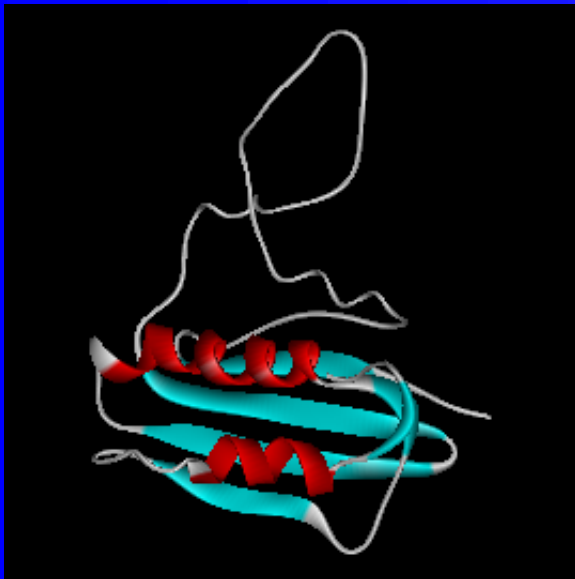

Monofunctional sensor



# Predictions

- Sensor 3-D structures for templates
  - ◆ EnvZ (Bifunctional)
  - ◆ CheA (Monofunctional)
- Sensor DNA sequences for threading
  - ◆ 2000 cases
  - ◆ Many organisms
- Functional predictions
  - ◆ Bifunctional
  - ◆ Monofunctional

# What is Common to These Successful Explanations of Design?

- **A limited number of possible variations on a theme**
- **Simple equations whose structure was amenable to qualitative analysis (and to exhaustive numerical analysis when necessary)**

# Summary

- Comparison Methodology
  - ◆ Mathematically controlled comparisons
  - ◆ “Ideal” control experiments
- Switching times for gene circuits
  - ◆ Physiology: Fast, reversible, robust
  - ◆ Differentiation: Slow, irreversible, sensitive
- Cross-talk between two-component modules
  - ◆ Insulators
  - ◆ Integrators

